



**Module for emergency stops and end position monitoring for movable guards**

#### Main features

- For safety applications up to SIL CL 3/PL e
- Input with 1 or 2 channels
- Choice between automatic start, manual start (CS AR-20 only) or monitored start (CS AR-21 only)
- Reduced housing width of 22.5 mm
- 2 NO safety contacts
- Supply voltage: 24 Vac/dc, 120 Vac, 230 Vac

#### Utilization categories

Alternating current: AC15 (50...60 Hz)

U<sub>e</sub> (V) 230

I<sub>e</sub> (A) 3

Direct current: DC13 (6 oper. cycles/min.)

U<sub>e</sub> (V) 24

I<sub>e</sub> (A) 4

#### Quality marks and certificates:



EC type examination certificate: IMQ CP 432 DM

UL approval: E131787

CCC approval: 2013010305640211

EAC approval: RU C-IT.AQ35.B.00454

#### Compliance with the requirements of:

Low Voltage Directive 2014/35/EU,

Machinery Directive 2006/42/EC,

EMC Directive 2014/30/EU

#### Technical data

##### Housing

Polyamide housing PA 66, self-extinguishing V0 acc. to UL 94

Protection degree:

IP40 (housing), IP20 (terminal strip)

Dimensions:

see page 295, design A

##### General data

SIL CL:

up to SIL CL 3 acc. to EN 62061

Performance Level (PL):

up to PL e acc. to EN ISO 13849-1

Safety category:

up to cat. 3 acc. to EN ISO 13849-1

Safety parameters:

see page 349

Ambient temperature:

-25°C...+55°C

Mechanical endurance:

>10 million operating cycles

Electrical endurance:

>100,000 operating cycles

Pollution degree:

external 3, internal 2

Impulse withstand voltage (U<sub>imp</sub>):

4 kV

Rated insulation voltage (U<sub>i</sub>):

250 V

Overvoltage category:

II

Weight:

0.2 kg

##### Supply

Rated supply voltage (U<sub>n</sub>):

24 Vac/dc; 50...60 Hz

120 Vac; 50...60 Hz

230 Vac; 50...60 Hz

Max. DC residual ripple in DC:

10%

Supply voltage tolerance:

±15% of U<sub>n</sub>

Power consumption AC:

< 5 VA

Power consumption DC:

< 2 W

##### Control circuit

Protection against short circuits:

PTC resistance, I<sub>h</sub>=0.5 A

PTC times:

Response time > 100 ms, release time > 3 s

Maximum resistance per input:

≤ 50 Ω

Current per input:

70 mA (typical)

Min. duration of start impulse t<sub>MIN</sub>:

> 100 ms

Response time t<sub>A</sub>:

< 50 ms

Release time in absence of power supply t<sub>R</sub>:

< 100 ms

Simultaneity time t<sub>c</sub>:

unlimited

##### In compliance with standards:

EN 60204-1, EN ISO 13855, EN 1037, EN ISO 12100, EN ISO 13850, EN 60529,

EN 61000-6-2, EN 61000-6-3, EN 61326-1, EN 60664-1, EN 60947-1, EN ISO 13849-1,

EN ISO 13849-2, EN 62061, UL 508, CSA C22.2 n° 14-95

##### Output circuit

Output contacts:

2 NO safety contacts

Contact type:

forcibly guided

Material of the contacts:

gold-plated silver alloy

Maximum switching voltage:

230/240 Vac; 300 Vdc

Max. current per contact:

6 A

Conventional free air thermal current (I<sub>th</sub>):

6 A

Max. total current Σ I<sub>th</sub><sup>2</sup>:

36 A<sup>2</sup>

Minimum current:

10 mA

Contact resistance:

≤ 100 mΩ

External protection fuse:

4 A

The number and the load capacity of output contacts can be increased by using expansion modules or contactors. see page 241-250.

#### Code structure

## CS AR-20V024

##### Start mode

**20** manual or automatic start

**21** monitored start

##### Connection type

**V** Screw terminals

**M** Connector with screw terminals

**X** Connector with spring terminals

##### Supply voltage

**024** 24 Vac/dc

**120** 120 Vac

**230** 230 Vac

#### Stock items

CS AR-20V024

#### Features approved by UL

Rated supply voltage (U<sub>n</sub>):

24 Vac/dc; 50...60 Hz

120 Vac; 50...60 Hz

230 Vac; 50...60 Hz

< 5 VA

Power consumption AC:

Power consumption DC:

Maximum switching voltage:

Max. current per contact:

Utilization category

230 Vac

6 A

C300

Notes:

- Use 60 or 75 °C copper (Cu) conductors, rigid or flexible, wire size 30-12 AWG.

- Tightening torque for terminal screws of 5-7 lb in.

- Only for 24 Vac/dc versions: power supply only with class 2 sources or with limited voltage and energy. (Supply from Remote Class 2 Source or limited voltage limited energy).



### Safety module CS AR-20 / CS AR-21

#### Pin assignment

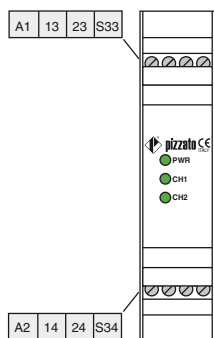

#### Internal block diagram

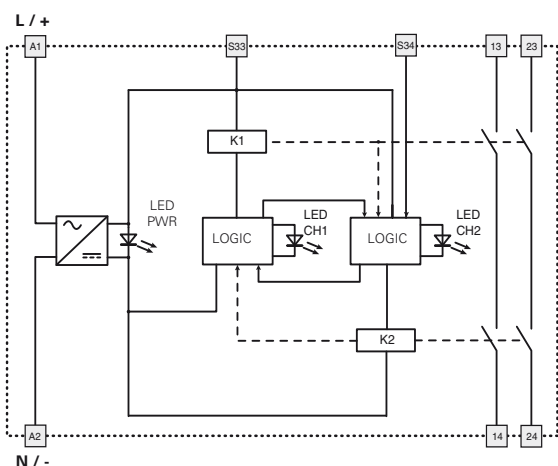

#### Function diagrams

Configuration with automatic start (CS AR-20)

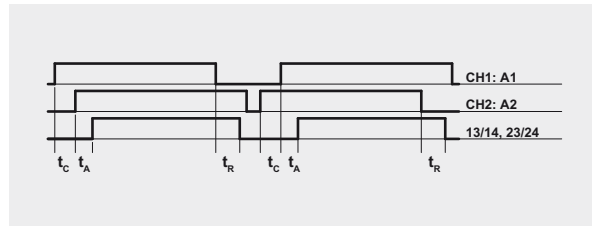

Configuration with monitored start (CS AR-21)

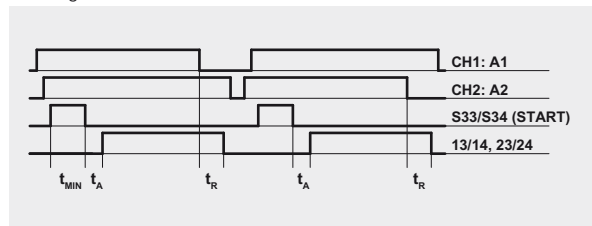

Configuration with manual start (CS AR-20)

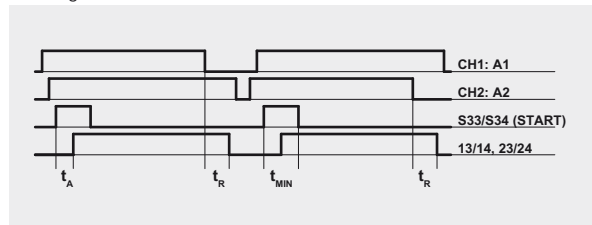

Legend:  
 $t_{MIN}$ : Min. duration of start impulse  
 $t_c$ : simultaneity time  
 $t_A$ : response time  
 $t_R$ : release time in absence of power supply

Notes:  
 The configurations with one channel are obtained taking into consideration the CH1:A1 input only. In this case it is necessary to consider time  $t_R$  referred to input CH1:A1, time  $t_A$  referred to input CH1:A1 and to the start, and time  $t_{MIN}$  referred to the start.

#### Input configuration

Emergency stop circuits	
Input configuration with manual start	
1 channel	2 channels

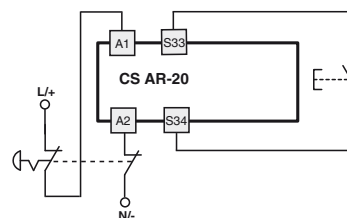
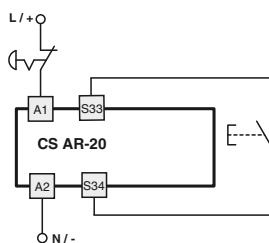

The diagram does not show the exact position of the terminals in the product

#### Automatic start

With regard to the indicated diagrams, bridge the start button between S33 and S34 in order to activate the automatic start module.

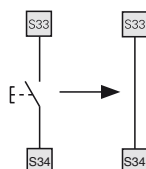

#### Monitored start

Use module CS AR-21 with the circuit diagrams for manual start.

#### Movable guard monitoring

The safety module can monitor emergency stop circuits and control circuits for movable guards. Replace the emergency stop contacts with the switch contacts.

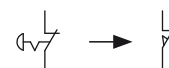

Items with code on green background are stock items

Application examples See page 251